

| POLE SHAFT SPECIFICATIONS        |   |                          |                  |                 |
|----------------------------------|---|--------------------------|------------------|-----------------|
| 1.                               | SHAFTS ARE ONE SECTION DESIGN FABRICATED FROM 6063 T6 ALUMINUM EXTRUSION-SPUN TAPERED.  |                          |                  |                 |
| 2.                               | BASE CASTING IS 356 T6 ALUMINUM. THE SHAFT TELESCOPES INTO THE BASE CASTING AND IS CIRCUMFERENTIALLY WELDED TOP AND BOTTOM.   |                          |                  |                 |
| 3.                               | ANCHOR BOLTS ARE "L" FORMED RODS HAVING A MINIMUM YIELD STRENGTH OF 55,000 P.S.I. FABRICATED FROM ASTM F1554 GR. 55 THEN PARTIALLY GALVANIZED PER ASTM A153 SPECIFICATIONS AND FURNISHED COMPLETE WITH 2 HEX NUTS AND 2 FLAT WASHERS. |                          |                  |                 |
| 4.                               | POLES SHALL HAVE A POLYESTER POWDER COAT FINISH IN A STANDARD COLOR.  |                          |                  |                 |
| POLE DIMENSIONS                  |   |                          |                  |                 |
| POLE HGT (FT.)                   | TOP DIA. (IN.)  | BOTTOM DIA. (IN.)        | GAGE             | MTG. HGT. (FT.) |
| 18'                              | 3.00  | 6.00                     | .156             | 18'             |
| BASE PLATE DIMENSIONS            |   |                          |                  |                 |
| BOLT CIRCLE (IN.)                | BASE PLATE DIM. (IN.)   | BOLT HOLE (IN.)          | PLATE THK. (IN.) |                 |
| 8.50-9.00                        | 10.75 SQ  | .81                      | .75              |                 |
| ANCHOR BOLT DIMENSIONS           |   |                          |                  |                 |
| ANCHOR BOLT DIA. (IN.)           |   | ANCHOR BOLT LENGTH (IN.) |                  |                 |
| .75                              |   | 20.00                    |                  |                 |
| ALLOWABLE WIND LOADING (SQ. FT.) |   |                          |                  |                 |
| WIND*                            | 80 MPH  | 90 MPH                   | 100 MPH          | 120 MPH         |
| EPA                              | 11.6  | 9.3                      | 7.4              | 4.7             |

\*WITH 1.3 GUST FACTOR

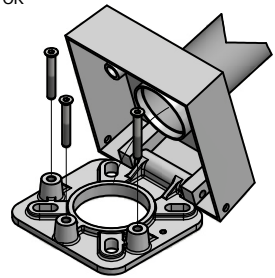

BASE ROTATION DETAIL VIEW

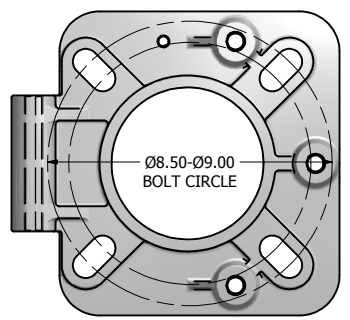

Ø8.50-Ø9.00  
BOLT CIRCLE

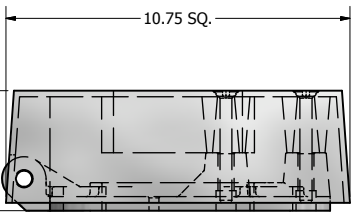

10.75 SQ.

3.50

10.75 X 10.75 X 3.50 THK. BASE CASTING

REMOVABLE CAP

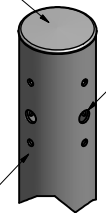

POLE SHAFT

DRILLED MOUNT OPTIONS

DRILLED PER FIXTURE REQUIREMENTS:  
D1- DRILLED FOR 1 FIXTURE  
D2- DRILLED FOR 2 FIXTURES AT 90° OR 180°  
D3- DRILLED FOR 3 FIXTURES AT 90° OR 120°  
D4- DRILLED FOR 4 FIXTURES

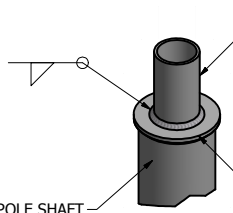

POLE SHAFT

TENON MOUNT OPTIONS

TENON MOUNT OPTIONS:  
T2- Ø2.38 OD X 4.00 LG  
T3- Ø3.00 OD X 5.00 LG  
T4- Ø4.00 OD X 6.00 LG

.25 THK. TENON MOUNT

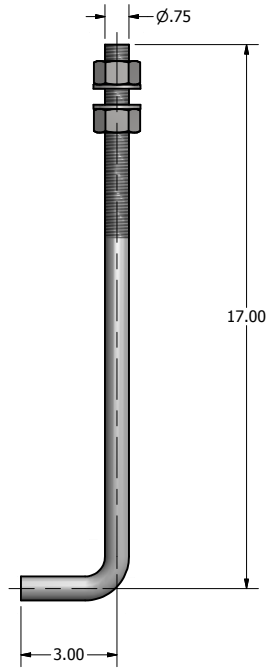

Ø.75 X 20.00 ANCHOR BOLT

POLE HEIGHT  
(FT.)

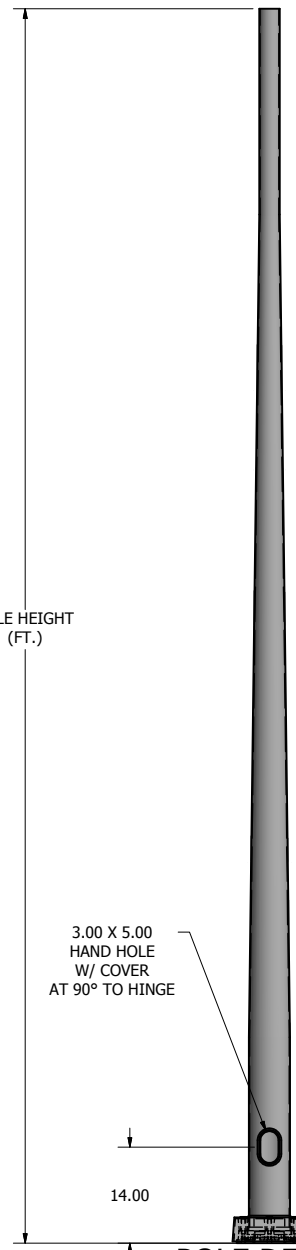

3.00 X 5.00  
HAND HOLE  
W/ COVER  
AT 90° TO HINGE

14.00

POLE DETAIL

lyte poles  
a DWM company

P.O. Box 340  
Eastpointe, MI 48021  
P: (586) 771-4610 | F: (586) 771-5527  
www.lytepoles.com

|                   |             |
|-------------------|-------------|
| DRAWN: M. HARVALA | 2/13/2015   |
| CHECKED           |             |
| REVISION:         | DATE:       |
| APPROVED:         |             |
| QUOTE:            |             |
| S.O.#             |             |
| REF:              | SCALE: NONE |

|   |        |
|---|--------|
| SOME GEOGRAPHICAL AREAS HAVE SPECIAL WIND CONDITIONS THAT CAN CREATE WIND INDUCED VIBRATIONS CAUSING A FATIGUE PROBLEM. NO METHOD HAS YET BEEN FOUND FOR PREDICTING DESTRUCTIVE LIGHTING POLE VIBRATION. THESE CONDITIONS ARE UNIQUE AND CANNOT BE GUARANTEED AGAINST, AND ARE THE RESPONSIBILITY OF A LOCAL SITE ENGINEER. |        |
| TITLE:  |        |
| CATALOG:  |        |
| DWG NO: 505-6015-18   | SIZE C |
| SHEET 1 OF 1  |        |

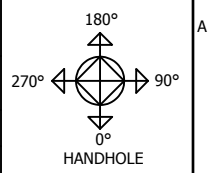

## example order number

| Fixture |         |        | Catalog Number |            |                | Mounting Type | Fixture Mounting Arrangement | Finish | Options         |        |             | Accessories      |        |             |                  |
|---------|---------|--------|----------------|------------|----------------|---------------|------------------------------|--------|-----------------|--------|-------------|------------------|--------|-------------|------------------|
| Brand   | Product | Number | Design         | Shaft Size | Wall Thickness |               |                              |        | Mounting Height | Design | Orientation | Height From Base | Design | Orientation | Height From Base |
|         |         |        | 101            | 40         | 11             | 20            | AB                           | T2     | DB              | WB-15  | @90         | 10'              | FH     | @180        | 9'               |

## build your order number

| Fixture |         |        | Catalog Number |            |                | Mounting Type | Fixture Mounting Arrangement | Finish | Options         |        |             | Accessories      |        |             |                  |
|---------|---------|--------|----------------|------------|----------------|---------------|------------------------------|--------|-----------------|--------|-------------|------------------|--------|-------------|------------------|
| Brand   | Product | Number | Design         | Shaft Size | Wall Thickness |               |                              |        | Mounting Height | Design | Orientation | Height From Base | Design | Orientation | Height From Base |
|         |         |        |                |            |                |               |                              |        |                 |        |             |                  |        |             |                  |
|         |         |        |                |            |                |               |                              |        |                 |        |             |                  |        |             |                  |

### mounting type

AB = Anchor Base  
EMB = Embedded (Direct Burial)

### fixture mounting arrangement

|         |      |
|---------|------|
| D1      | D4   |
| D2@90   | T2   |
| D2@180  | T2.5 |
| D3@90   | T3   |
| D3@120* | T4   |

### finish

WH = White  
TWH = Textured White  
DB = Dark Bronze  
TMB = Textured Medium Bronze  
HB = Harvest Bronze  
NB = New Bronze  
SL = Silver  
MGY = Medium Gray  
GR = Gray  
TGR = Textured Gray  
GM = Graphite Metallic  
DP = Dark Platinum  
MA = Matte Aluminum  
PSP = Platinum Silver  
BK = Black  
TBK = Textured Black  
MG = Moss Green

### options

CMB = Camera Mounting Bracket  
CMP = Camera Mounting Plate  
WB-15 = Mounting Bracket  
WC = Welded Coupling (denote size)  
WN = Welded Nipple (denote size)  
Festoon = Festoon Provision  
CSBC = Custom Steel Base Cover  
VD = Vibration Dampener  
GFCI/IUC = Ground Fault Circuit Interrupter with In-Use Cover  
UL = UL Listed

Note: N/A = Not Applicable

### accessories

TB = Transformer Base\*  
ABS-BC = ABS Base Cover\*  
LW = Lowering Winch  
LW-ELECTRIC = Electric Lowering Winch  
BA = Banner Arm  
FH = Flag Holder  
PTTA = Pole Top Tenon Adapter\*

\*Round poles only

Refer to the Mounting Orientation Guide on the next page of this file.

Contact us for custom colors.

\*See our online product catalog for complete catalog numbers of these options and accessories.

\*\* UL Listed labeling is available for catalog steel and aluminum poles—both Commercial & Industrial and Roadway. UL Listed labeling is not available for brackets. UL Listing must be specified at the time of order.